

# C4.PO



## AUTONOMIA

2 litri di soluzione disinfettante  
60 minuti

## AUTONOMY

2 litres of disinfectant solution  
60 minutes

## PRESTAZIONI (resa in 1 ora)

500/1000 mq di superfici trattate

## PERFORMANCES (in 1 hour)

500/1000 sqm of treated surfaces



## DATI TECNICI

Alimentazione elettrica: 230 V - 50 Hz  
115 V - 60 HZ

Capacità serbatoi:  
• acqua 2.0 lt  
• disinfettante 2.0 lt

Peso a vuoto: 26 Kg ca.

### ALTRE CARATTERISTICHE:

- Maniglie Alluminio verniciato
- Componenti principali interne Inox aisi 304
- Scocca Acciaio verniciato
- Ruote in gomma sintetica Antitraccia
- Lunghezza tubo lancia 230cm.

## TECHNICAL DATA

Power supply: 230 V - 50 Hz  
115 V - 60 HZ

Capacity of tanks:  
• water 2.0 lt  
• disinfectant 2.0 lt

Empty weight: 26 Kg about

### TECHNICAL FEATURES:

- Handles Painted aluminum
- Inside main components Stainless steel aisi 304
- Body Painted steel
- Synthetic rubber wheel Non-marking
- Flex tube length 230cm.

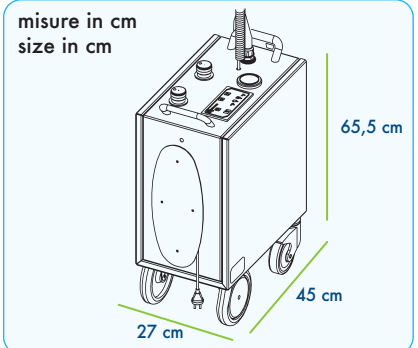



MANIGLIE DI MOVIMENTAZIONE  
HANDLING HANDLE

LANCIA EROGAZIONE  
DISPENSING LANCE

INDICATORE PRESSIONE  
PRESSURE GAUGE

SERBATOIO ACQUA  
WATER TANK

AVVOLGICAVO  
CABLE HOLDER

SERBATOIO DISINFETTANTE  
DISINFECTANT TANK



QUADRO COMANDI  
CONTROL PANEL

SPIA FINE ACQUA  
WATER FAIL  
WARNING LIGHT

SPIA FINE DISINFETTANTE  
DISINFECTANT FAIL  
WARNING LIGHT

TASTI ACCESO/SPENTO  
POWER ON/OFF

RESISTENZA  
RESISTANCE

FUNZIONE HYGIENIO  
HYGIENIO FUNCTION

SPRINTER  
SPRINTER

